

# Wind Farms

# Wind Farms General

- Wind resource through the middle of the US into southern Canada
- Power sales through either long term agreements or in some areas spot market
- Typical wind farm capacity factors around 30 – 35%
- Very tight margins
- Renewable Energy Credits (RECs)
- Projects are typically geared (approximately 60% of TIC)
- General industry slow down due finance crunch, lower gas prices leading to lower power prices and states accomplishing their renewable energy standards (2010 approximately 20% of 2009 installed capacity through 3Q10)
- Transmission constraints

# Typical Wind Farm Layout

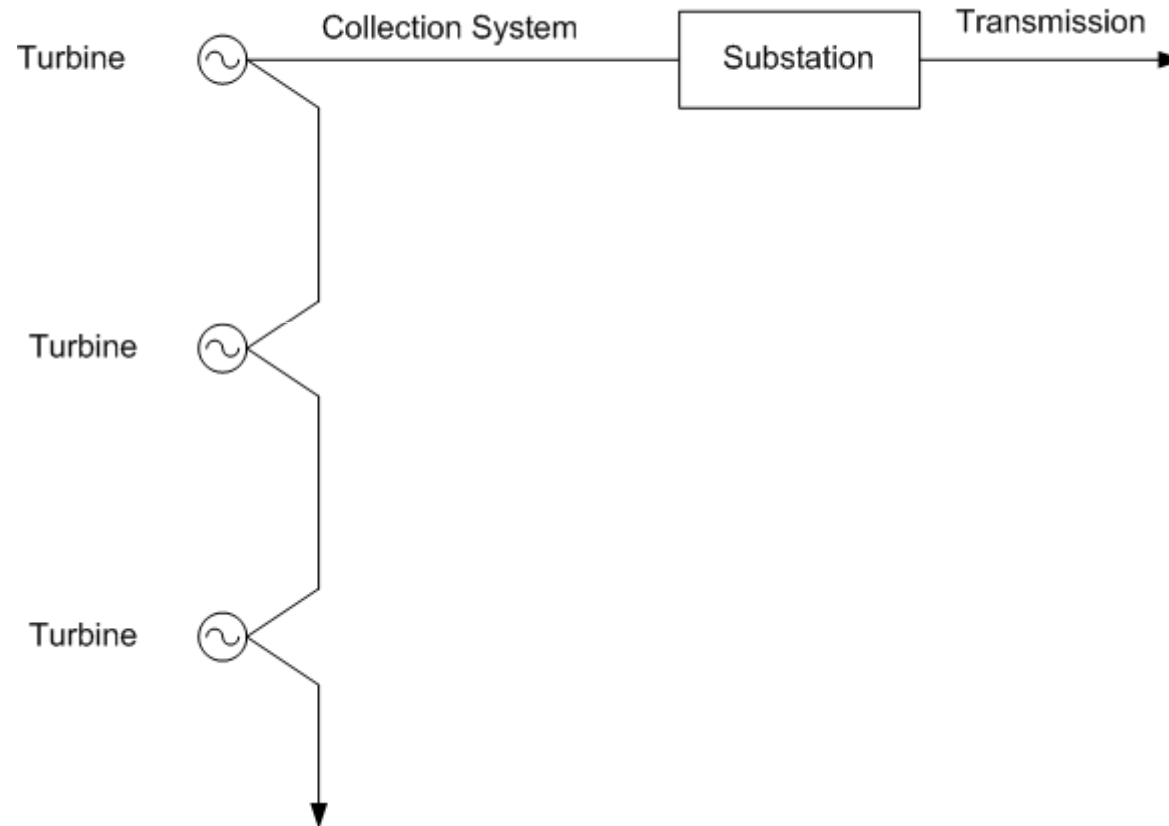

# Equipment

- Wind Turbine Generators (WTGs)
  - WTG major components
    - Tubular tower sections (stacked approx. 80m tall)
    - Nacelle (gearbox and generator)
    - Rotors
    - SCADA
  - Typically the OEM provides O&M for the wind farm 2 - 10 years after S/U
  - OEM responsible for availability during warranty

# Wind Turbine

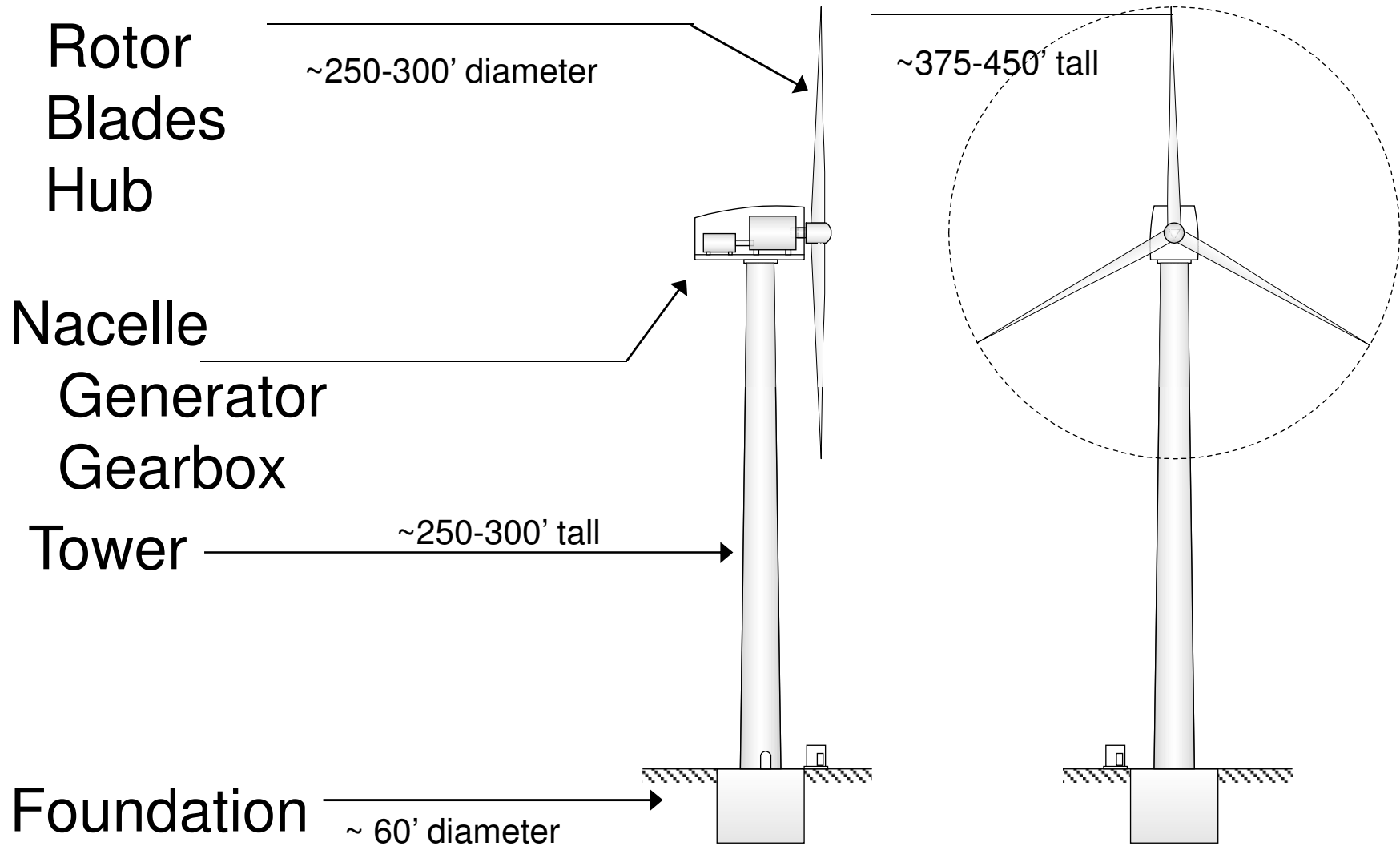

# Lifting a Tower Section



# Nacelle Installation



# Flying the Rotor



# Balance of Plant

- Roads
  - Site access roads
  - Turbine access roads – typically approx. 35'W to allow for crane walking between WTGs
- Foundations
  - Spread foundation
  - P&H type foundation (modified monopile)
- Collection System
  - Underground 35kV directly buried
- Substation
  - 35KV up to the distribution voltage (138kV – 500kV)
- Transmission
  - HV transmission to the Point of Interconnect (POI) with the utility

# Foundations

- Design Driven By
- Wind Loading
  - Soil Conditions
  - Seismic Requirements

Mat Foundation

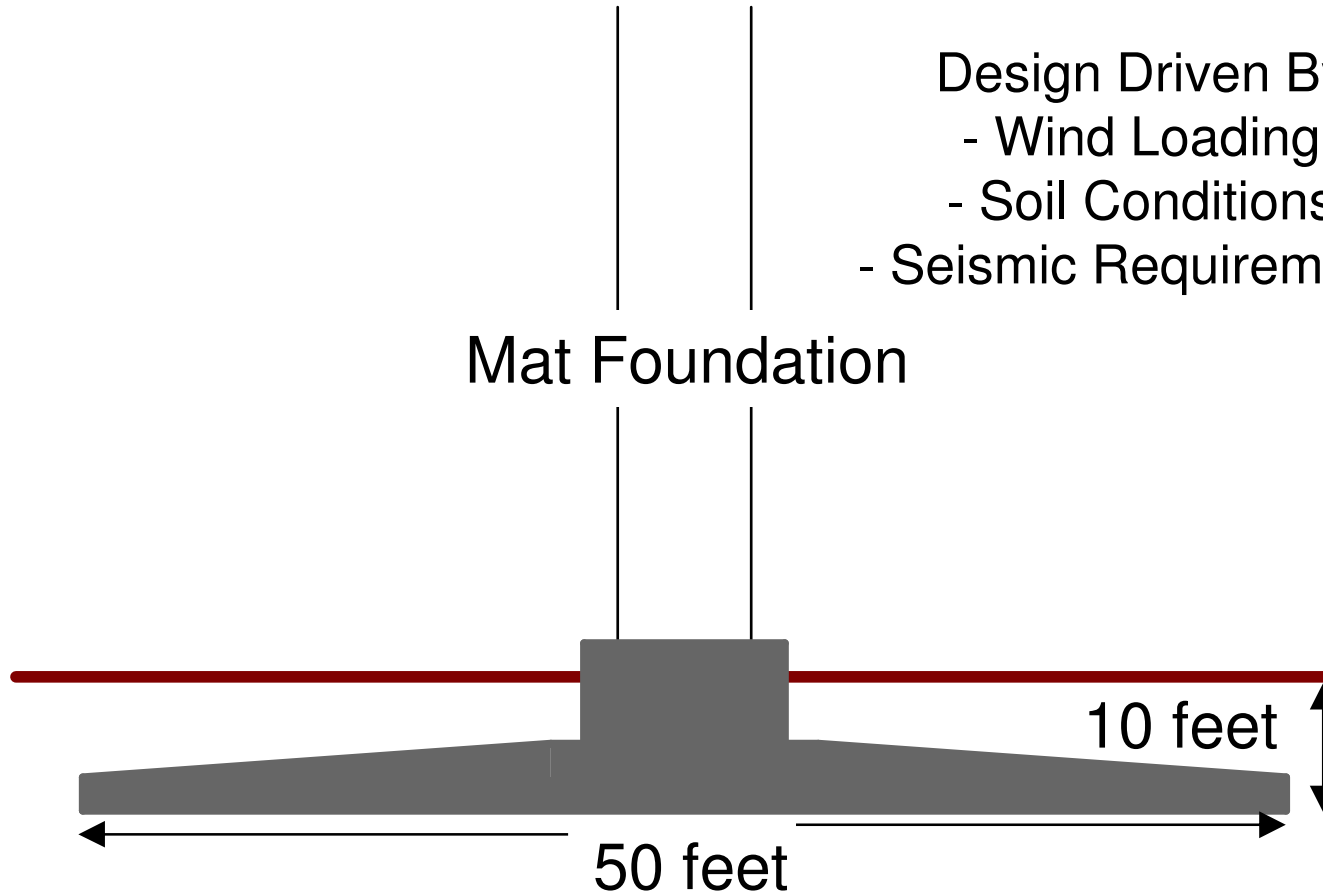

Pier Foundation

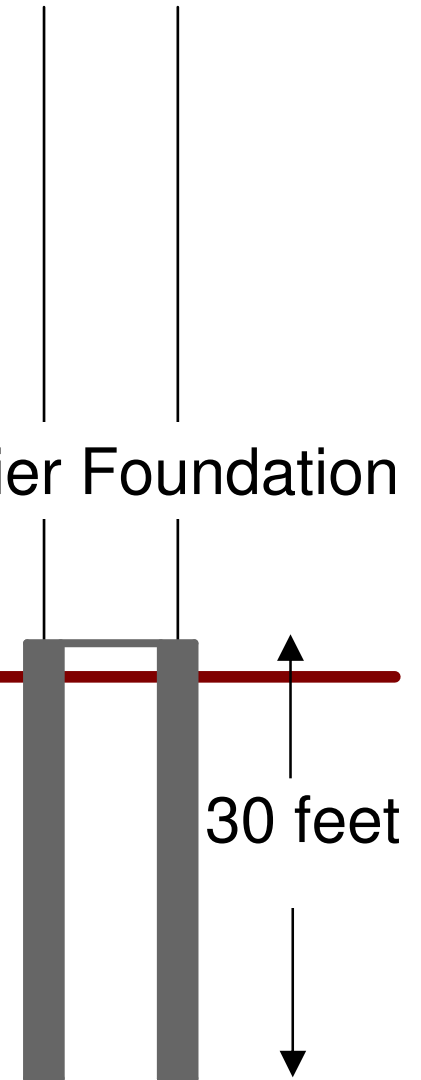



FOUNDATION CONSTRUCTION

# Turbine Foundation



# Logistics

- Logistics are extremely important
- Deliveries of turbine components
  - Oversize and overweight – permit constraints
  - Turning radius – approx. 130' R
  - % grade
- Concrete – on site batch plant
  - Pour 1000 cy/day (100 trucks/day)
- Crusher run – aggregate for roads

# Breakdown of TIC by Category

Category	% of TIC
WTGs	65%
BOP - Roads	6%
BOP - Foundations	6%
BOP – Erection	6%
BOP – Collection System	6%
BOP – Substation/Transmission	6%
Owner's Costs (incl. DDE)	5%

# Schedule

- Erection greatly dependant upon weather (max 25 mph wind) – typically at most sites high wind October - May
- Design one and build many approach
- Assembly line construction

# Mt Storm Project

- JV between Shell and Dominion
- Located along a ridgeline in West Virginia
- > 28 miles of graveled roads (40'w)
- > 500 acres of timbering
- > 1M lf of 35kV power cables
- > 10K tons of rebar
- >14K anchor bolts
- > 65k cy of concrete (5000 psi)
- > 1300 lifts of over 100,000# (over 250 of these were over 90m in height)



*ROTOR ERECTION*



Rotor Erection



**ROTOR ASSEMBLY**

Substation (35 – 500kV)

